



10. Specifications.

The new BMW 3 Series Sedan. BMW 320d EfficientDynamics Edition, BMW 320d.

		BMW 320d EfficientDynamics Edition	BMW 320d
Body			
No. of doors/seats		4 / 5	4 / 5
Length/width/height (unladen)	mm	4624 / 1811 / 1416	4624 / 1811 / 1429
Wheelbase	mm	2810	2810
Track, front/rear	mm	1543 / 1583	1543 / 1583
Ground clearance	mm	125	140
Turning circle	m	11.3	11.3
Tank capacity	approx. l	57	57
Cooling system incl. heating	l	7	7
Engine oil ¹⁾	l	5.2	5.2
Weight, unladen, to DIN/EU	kg	1415 / 1490	1420 / 1495
Max load to DIN	kg	550	550
Max permissible weight	kg	1965 (1975)	1970 (1980)
Max axle load, front/rear	kg	905 / 1120	905 / 1120
Max trailer load, braked (12%/unbraked)	kg	1600 / 745	1600 / 745
Max roof load/towbar download	kg	75 / 75	75 / 75
Luggage comp. capacity	l	480	480
Air drag	c _d x A	0.26 x 2.20	0.27 x 2.20
Engine			
Config./No. of cyls./valves		R / 4 / 4	R / 4 / 4
Engine technology		Common rail direct inject turbocharger with variable i geometry	
Effective capacity	cm ³	1995	1995
Bore/stroke	mm	90.0 / 84.0	90.0 / 84.0
Compression ratio	:1	16.5	16.5
Fuel grade		diesel	diesel
Output	kW/hp	120 / 163	135 / 184
at	min ⁻¹	4000	4000
Torque	Nm	380	380
at	min ⁻¹	1750-2750	1750-2750
Electrical system			
Battery/Installation	Ah/-	90 / luggage comp.	90 / luggage comp.
Alternator	AW	180 / 2520	180 / 2520
Driving dynamics and safety			
Suspension, front		Aluminium double-joint spring strut axle with displaced camber, small positive steering roll radius, transverse force compensation, anti-dive	
Suspension, rear		Five-link axle in lightweight construction	
Brakes, front		Single-piston swing-calliper disc brakes / vented	
Brakes, rear		Single-piston swing-calliper disc brakes / vented	
Driving stability systems		Standard: DSC incl. ABS and DTC (Dynamic Traction Control), CBC (Cornering Brake Control), DBC (Dynamic Brake Control), Dry Braking function, Fading Compensation, Start-Off Assistant	
Safety equipment		Standard: airbags for driver and front passenger, side airbags for driver and front passenger, head airbags for front and rear seats, three-point inertia-reel seatbelts on all seats with belt latch tensioner and belt force limiter at the front, crash-activated head restraints at the front, crash sensors, Tyre Defect Indicator	
Steering		Electromechanical rack-and-pinion power steering	
Steering ratio, overall	:1	15.1	15.1
Tyres, front/rear		205/60 R16 92W	205/60 R16 92W
Rims, front/rear		7.0J x 16 light-alloy	7.0J x 16 light-alloy

The new BMW 3 Series Sedan. BMW 320d EfficientDynamics Edition, BMW 320d.

			BMW 320d EfficientDynamics Edition	BMW 320d
BMW ConnectedDrive				
Comfort			Optional: BMW Assist incl. Enquiry Service, remote-control functions and V-Info+ (Traffic Info plus), RTTI, BMW TeleServices, mobile device integration	
Infotainment			Optional: internet access, BMW Online incl. Park Info, National Info, Google Local Search, News, Realtime Weather, BMW Routes, Office functions, Bluetooth Audio Streaming and Online Update Music Tracks	
Safety			Optional: Adaptive Headlights with cornering lights, variable light distribution and adaptive headlight range control, High-Beam Assistant, Park Distance Control, rear view camera, Surround View incl. Side View and Top View, BMW Night Vision with pedestrian recognition, Head-Up Display, Parking Assistant, Lane Change Warning, Lane Departure Warning, Speed Limit Info, Advanced eCall	
Transmission				
Type of gearbox			Six-speed manual (optional: eight-speed automatic)	
Gear ratios	I	:1	4.110 (4.714)	4.110 (4.714)
	II	:1	2.248 (3.143)	2.248 (3.143)
	III	:1	1.403 (2.106)	1.403 (2.106)
	IV	:1	1.000 (1.667)	1.000 (1.667)
	V	:1	0.802 (1.285)	0.802 (1.285)
	VI	:1	0.659 (1.000)	0.659 (1.000)
	VII	:1	----- (0.839)	----- (0.839)
	VIII	:1	----- (0.667)	----- (0.667)
	R	:1	3.727 (3.295)	3.727 (3.295)
Final drive		:1	2.929 (2.813)	3.231 (2.813)
Performance				
Power-to-weight ratio		kg/kW	11.8 (11.9)	10.5 (10.6)
Output per litre		kW/l	60.2	67.7
Acceleration	0–100 km/h	s	8.0 (8.1)	7.5 (7.6)
	0–1000 m	s	28.7 (28.4)	27.7 (27.7)
in 4th gear	80–120 km/h	s	6.7 / 9.1 (-)	5.9 / 7.5 (-)
Top speed		km/h	230 (225)	235 (230)
BMW EfficientDynamics				
BMW EfficientDynamics standard features			Brake Energy Regeneration, Optimum Shift Indicator (manual gearbox), on-demand operation of ancillary units, intelligent lightweight construction, EPS (electric power steering), tyres with reduced rolling resistance, map-controlled oil pump, disengageable a/c compressor	
Fuel consumption EU²⁾				
Urban		l/100km	5.2 (5.0)	5.8 (5.4)
Extra-urban		l/100km	3.5 (3.6)	3.8 (3.9)
Combined		l/100km	4.1 (4.1)	4.5 (4.4)
CO ₂		g/km	109 (109)	119 (117)
Emission rating			EU5	EU5

Specifications apply to ACEA markets; data relevant to homologation applicable in part only to Germany (weight)
Figures in brackets apply to automatic transmission

¹⁾ Oil change volume

²⁾ Fuel consumption and CO₂ emissions vary according to the wheel and tyre sizes selected

The new BMW 3 Series Sedan.

BMW 328i, BMW 335i.

		BMW 328i Sedan	BMW 335i Sedan
Body			
No. of doors/seats		4 / 5	4 / 5
Length/width/height (unladen)	mm	4624 / 1811 / 1429	4624 / 1811 / 1429
Wheelbase	mm	2810	2810
Track, front/rear	mm	1531 / 1572	1531 / 1572
Ground clearance	mm	140.	140
Turning circle	m	11.3	11.3
Tank capacity	approx. l	60	60
Cooling system incl. heating	l	7 (7.6)	6.7 (7.2)
Engine oil ¹⁾	l	5.75	6.5
Weight, unladen, to DIN/EU	kg	1430 / 1505	1510 / 1585
Max load to DIN	kg	550	550
Max permissible weight	kg	1980 (2005)	2060 (2070)
Max axle load, front/rear	kg	920 / 1140	965 / 1145
Max trailer load, braked (12%/unbraked)	kg	1600 / 745	1700 / 750
Max roof load/towbar	kg	75 / 75	75 / 75
Luggage comp. capacity	l	480	480
Air drag	c _d x A	0.29 x 2.20	0.30 x 2.20
Engine			
Config./No. of cyls./valves		in-line / 4 / 4	in-line / 6 / 4
Engine technology		BMW TwinPower Turbo, High Precision Direct Petrol Injection, fully variable valve control (VALVETRONIC)	
Effective capacity	cm ³	1997	2979
Bore/stroke	mm	90.1 / 84.0	89.6 / 84.0
Compression ratio	:1	10.0	10.2
Fuel grade		min RON 91	min RON 91
Output	kW/hp	180 / 245	225 / 306
at	min ⁻¹	5000-6500	5800-6000
Torque	Nm	350	400
at	min ⁻¹	1250-4800	1200-5000
Electrical system			
Battery/Installation	Ah/-	90 / luggage comp.	90 / luggage comp.
Alternator	AW	170 / 2380	210 / 2940
Driving dynamics and safety			
Suspension, front		Aluminium double-joint spring strut axle with displaced camber, small positive steering roll radius, transverse force compensation, anti-dive	
Suspension, rear		Five-link axle in lightweight construction	
Brakes, front		Single-piston swing-calliper disc brakes / vented	
Brakes, rear		Single-piston swing-calliper disc brakes / vented	
Driving stability systems		Standard: DSC incl. ABS and DTC (Dynamic Traction Control), CBC (Cornering Brake Control), DBC (Dynamic Brake Control), Dry Braking function, Fading Compensation, Start-Off Assistant	
Safety equipment		Standard: airbags for driver and front passenger, side airbags for driver and front passenger, head airbags for front and rear seats, three-point inertia-reel seatbelts on all seats with belt latch tensioner and belt force limiter at the front, crash-activated head restraints at the front, crash sensors, Tyre Defect Indicator	
Steering		Electromechanical rack-and-pinion power steering	
Steering ratio, overall	:1	15.1	15.1
Tyres, front/rear		225/50 R17 94W	225/50 R17 94W
Rims, front/rear		7.5J x 17 light-alloy	7.5J x 17 light-alloy

The new BMW 3 Series Sedan.

BMW 328i, BMW 335i.

BMW 328i Sedan BMW 335i Sedan

BMW ConnectedDrive

Comfort	Optional: BMW Assist incl. Enquiry Service, remote-control functions and V-Info+ (Traffic Info plus), RTTI, BMW TeleServices, mobile device integration
Infotainment	Optional: internet access, BMW Online incl. Park Info, National Info, Google Local Search, News, Realtime Weather, BMW Routes, Office functions, Bluetooth Audio Streaming and Online Update Music Tracks
Safety	Optional: Adaptive Headlights with cornering lights, variable light distribution and adaptive headlight range control, High-Beam Assistant, Park Distance Control, rear view camera, Surround View incl. Side View and Top View, BMW Night Vision with pedestrian recognition, Head-Up Display, Parking Assistant, Lane Change Warning, Lane Departure Warning, Speed Limit Info, Advanced eCall

Transmission

Type of gearbox	Six-speed manual (optional: eight-speed automatic)		
Gear ratios	I	:1	3.683 (4.714) 4.110 (4.714)
	II	:1	2.062 (3.143) 2.315 (3.143)
	III	:1	1.313 (2.106) 1.542 (2.106)
	IV	:1	1.000 (1.667) 1.179 (1.667)
	V	:1	0.809 (1.285) 1.000 (1.285)
	VI	:1	0.677 (1.000) 0.846 (1.000)
	VII	:1	----- (0.839) ----- (0.839)
	VIII	:1	----- (0.667) ----- (0.667)
	R	:1	3.348 (3.295) 3.727 (3.295)
Final drive		:1	3.909 (3.154) 3.231 (3.154)

Performance

Power-to-weight ratio	kg/kW		7.9 (8.1)	6.7 (6.8)
Output per litre	kW/l		90.1	75.5
Acceleration	0–100 km/h	s	5.9 (6.1)	5.5 (5.5)
	0–1000 m	s	25.4 (25.6)	24.3 (24.4)
in 4th gear	80–120 km/h	s	5.4 / 6.9 (-)	5.2 / 6.1 (-)
Top speed	km/h		250 (250)	250 (250)

BMW EfficientDynamics

BMW EfficientDynamics standard features	Brake Energy Regeneration, Optimum Shift Indicator (manual gearbox), on-demand operation of ancillary units, intelligent lightweight construction, electromechanical power steering, tyres with reduced rolling resistance, map-controlled oil pump, disengageable a/c compressor
---	---

Fuel consumption EU²⁾

Urban	l/100km	8.5 (8.2)	11.1 (10.2)
Extra-urban	l/100km	5.2 (5.2)	6.1 (5.5)
Combined	l/100km	6.4 (6.3)	7.9 (7.2)
CO ₂	g/km	149 (147)	186 (169)
Emission rating		EU5	EU5

Specifications apply to ACEA markets; data relevant to homologation applicable in part only to Germany (weight)
Figures in brackets apply to automatic transmission

¹⁾ Oil change volume

²⁾ Fuel consumption and CO₂ emissions depend on the selected tyre format

11. Output and torque diagrams. The new BMW 3 Series Sedan. BMW 328i.

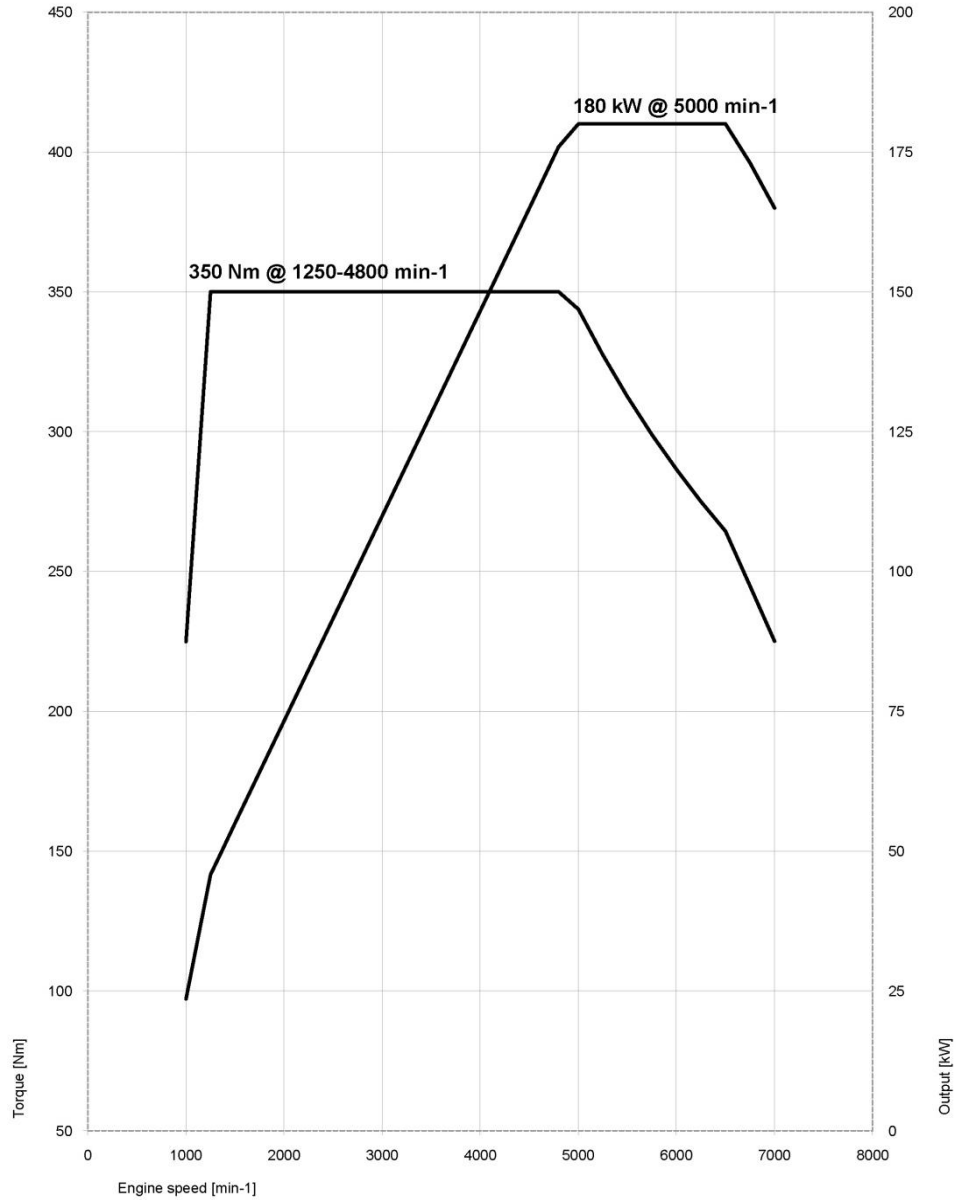

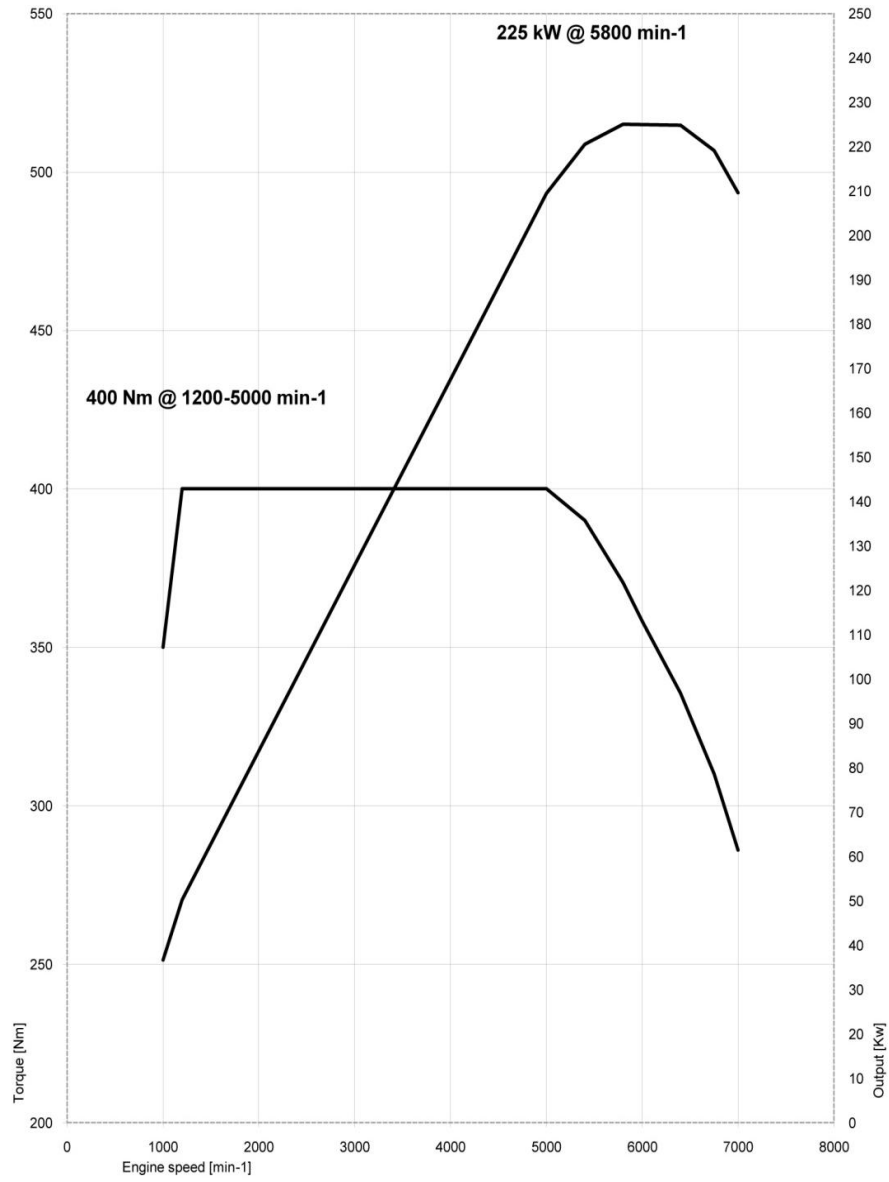

BMW 320d EfficientDynamics Edition.

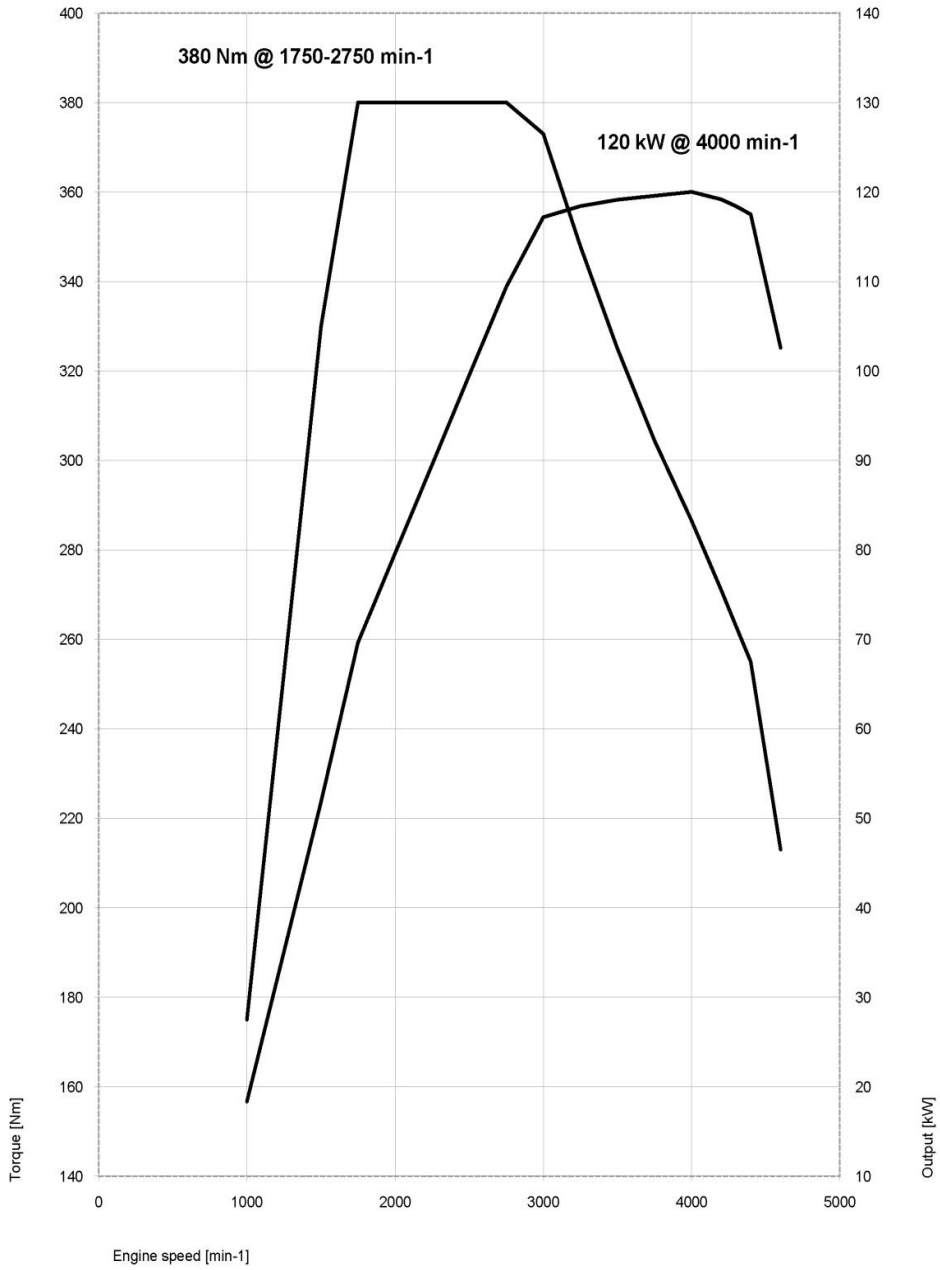

BMW 320d.

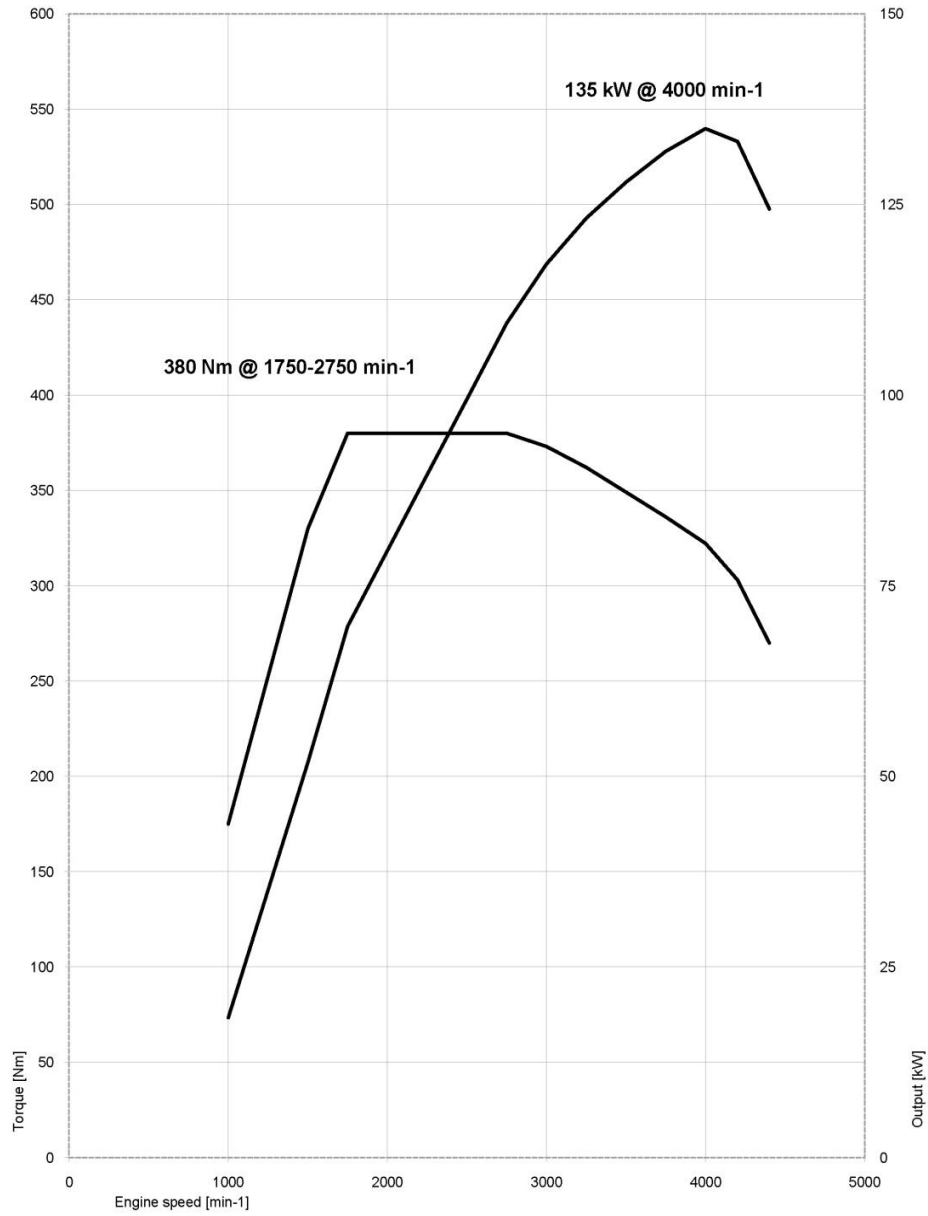

12. Exterior and interior dimensions.

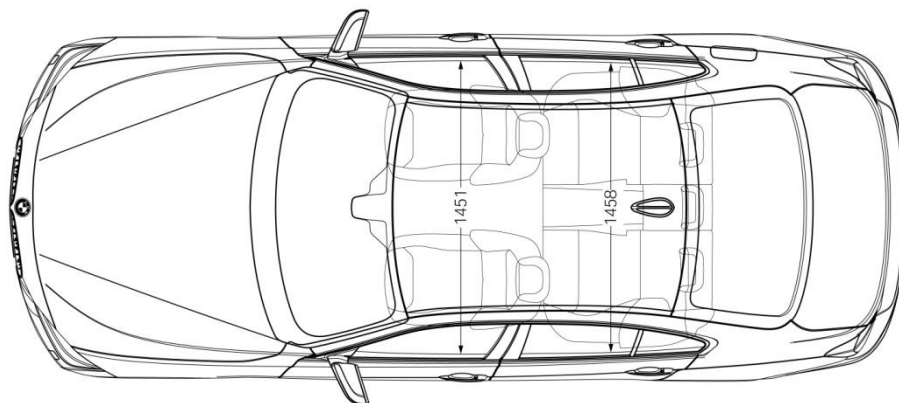
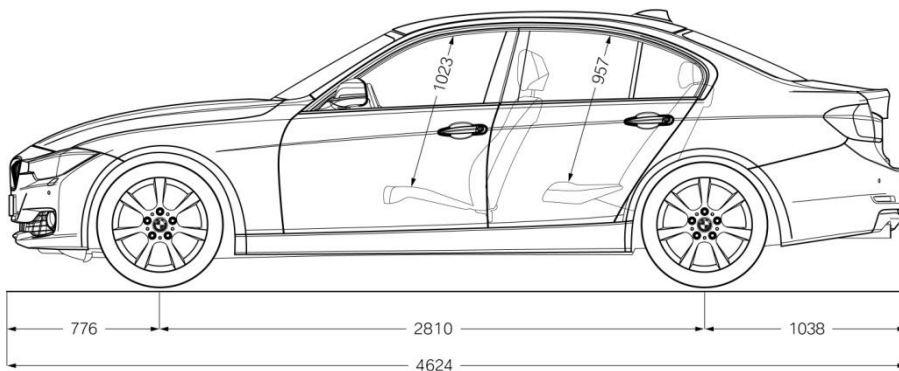
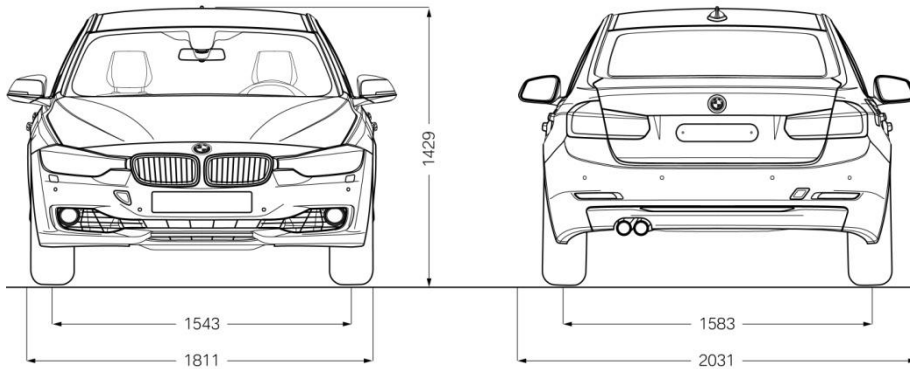

Ansicht

F30

Außen- und Innenabmessungen

BMW AG Digitale Medien PA-412